

www.sintef.no



**SINTEF Energy Research**

Address: NO-7465 Trondheim,
NORWAY
Reception: Sem Sælands vei 11
Telephone: +47 73 59 72 00
Telefax: +47 73 59 72 50

www.energy.sintef.no

Enterprise No.:
NO 939 350 675 MVA

TEST REPORT

TITLE

PD measurement on oil-immersed transformer

TEST CONDUCTED BY

Horst Förster, Rolf Hegerberg

CLIENT(S)

Møre Trafo AS, 6230 Sykkylven, Norway

LR NO.

LR F2460

DATE

2008-05-19

CLIENT'S REF.

Kårstein Longva

ELECTRONIC FILE CODE

08051910443

RESPONSIBLE

Rolf Hegerberg

PROJECT NO.

14X47043

NUMBER OF PAGES

5

TEST LOCATION

High voltage laboratory, SINTEF Energy Research

TEST OBJECT

Transformer OTK5538, transf. nr 0800058, 420/22000 V, 200 kVA, Yyn0

TEST OBJECT RECEIVED

2008-05-06

TEST PROGRAM

Pd measurement according to IEC 60076-13 (2006-05) sub-cl 12.1

DATE OF TEST

2008-05-08

SUMMARY

The transformer fulfilled the requirements of the standard.

The test results relate only to the items tested

The report is the client's property and cannot be given to a third party without the client's written consent.
The report shall not be reproduced except in full without the written approval of SINTEF Energy Research.

KEYWORDS

SELECTED BY
AUTHOR(S)

Transformer

PD measurement

IEC 60076-13

TABLE OF CONTENTS

	<u>Page</u>
1 Observers.....	3
2 Test object	3
3 Test program.....	3
4 Test results.....	3
5 Conclusion.....	3
Circuit diagram	4

1 OBSERVERS

The tests were observed by Kårstein Longva and Arnulf Karlsvik, representing Møre Trafo AS.

2 TEST OBJECT

One oil-immersed transformer 420/22000 V; 200 kVA produced by Møre Trafo AS.
Designation OTK5538, serial No. 0800058, connection Yyn0

3 TEST PROGRAM

The transformer was tested according to sub-cl 12.1 of IEC 60076-13 (2006-05).
The transformer was magnetised from the lv windings and one HV terminal earthed during pd-measurements on the other HV terminals (see circuit diagram).

4 TEST RESULTS

The test results are summarised in the table:

Measured on phase	A	B	C	Requirement
Earthed phase	C	C	A	
U= 1.8U _r =22,9 kV; t = 30 sec	-	-	-	-
U= 1.4U _r =17,8kV; t = 5 min	50 pC	25 pC	40 pC – 30 pC	< 100 pC
U= 1.2U _r =15,2 kV; t = 30 sec	< 10 pC	< 10 pC	≈ 10 pC	< 50 pC

Where a range of values are given, the measured PD amplitude decreased during the measuring period.

5 CONCLUSION

The transformer fulfilled the requirements of IEC 60076-13 (2006-05), sub-cl 12.1.

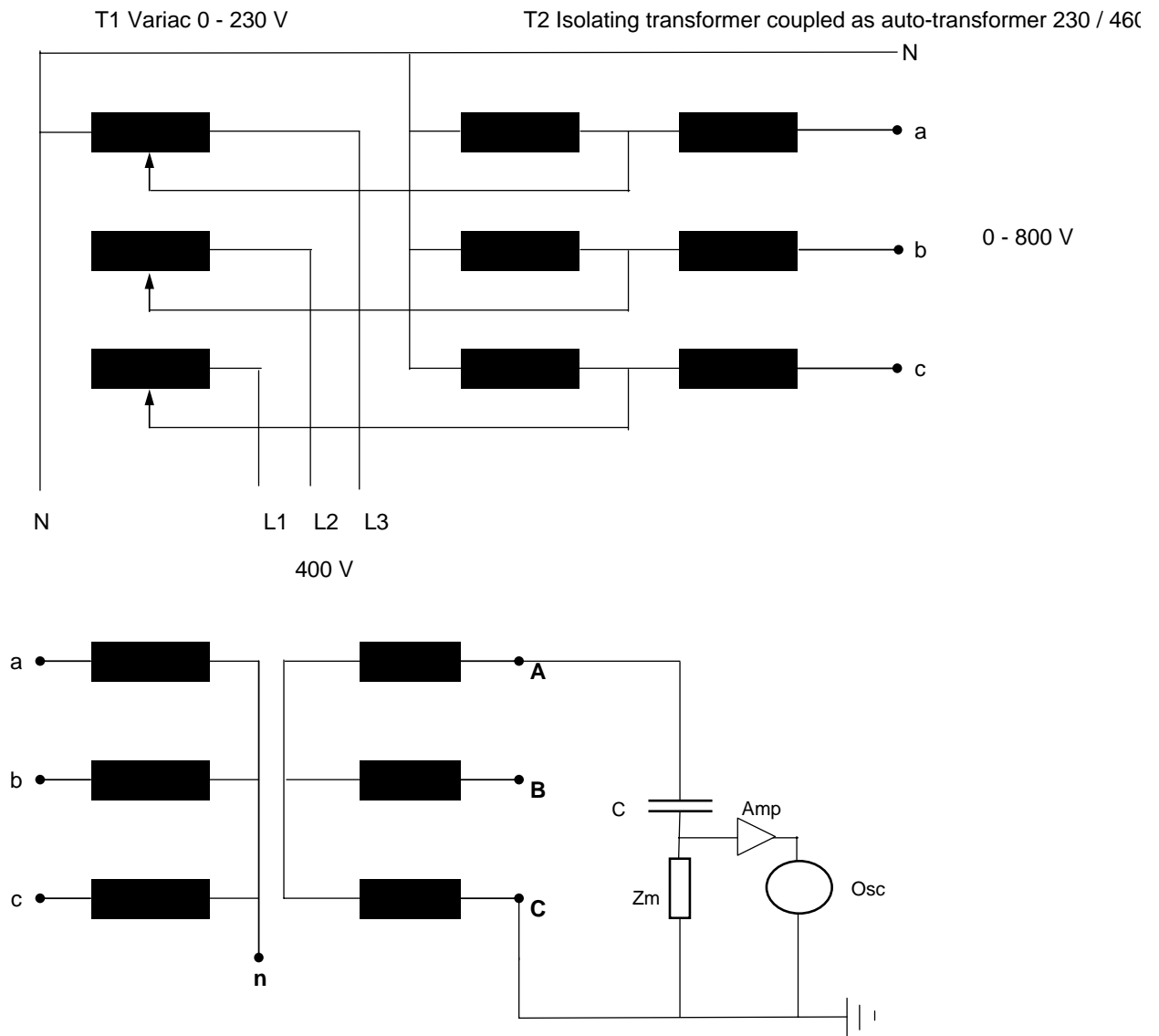
CIRCUIT DIAGRAM

Equipment:

T1: Variac B01-0466

T2: Isolating transformer B01-0576 (connected as autotransformer)

Coupling capacitor C: 750pF/120 kV K03-0106

 Shunt Z_m : I06-0397

Amplifier Amp: N07-0102 / N07-0067-1

PD calibrator: H02-0131

Oscilloscope: G04-0027

SINTEF Energiforskning AS
Adresse: 7465 Trondheim
Telefon: 73 59 72 00

SINTEF Energy Research
Address: NO 7465 Trondheim
Phone: + 47 73 59 72 00